



Unlock ***Savings*** with
our ***Revolutionary***
PMA Solutions



AGENDA

- Introducing our Speaker
- A brief overview of FCAH Aerospace
- Overview of our PMA Solutions, including Girt Assembly, Cylinders, Roller Systems, and Portability Studs
- Questions/Closing Statement

Christopher Cartwright
Engineering Manager



About FCAH Aerospace



FCAH Aerospace includes a family of brands that collectively provide comprehensive aftermarket aviation solutions, focused on delivering high-quality OEM, PMA, and aftermarket parts, maintenance, repair, overhaul, storage, disassembly, emergency equipment, and customer service with care and urgency.

Our brands include Air Cargo Equipment, AVI Aviation and its divisions, Cargo Repair, Cobalt Aero Services, and First Class Air Support.

Visit our website to learn more
<https://fcahaerospace.com>

Total Square Footage

Over 434,000 square feet of warehouse space

Locations

10 locations and 15 distribution centers

Customers

Supporting over 750 Customers

Solutions

- Offering Specialized repair solutions for cargo loading systems and components
- Providing More than 2M Parts including PMA
- Reducing cost by up to 60% with DER Capabilities
- Specializes in maintaining, repairing, and overhauling of large components
- Manufacturing Compact Lightweight Survival Rafts for aviation Industry
- Supporting your End of Life with Teardown capabilities

PMA Solutions – What is the Advantage?

At FCAH Aerospace, we are committed to providing innovative solutions that can help support your business objectives. Our PMA solutions are designed to help your organization reduce costs, increase durability, and improve turn-around time. We have Girt Assembly, Cylinders, and Portable Studs that support various fleets that are available for purchase today. Additionally, we are the exclusive distributor of PMA roller systems for cargo aircraft through First Class Air Support.



Ease of Maintenance



**Reduced Cost and
Increased Durability**



Same Quality or Better



**Improved
Turn-Around-Time**

AVI Aviation's PMA Parts



AVI Aviation offers PMA cylinders, reservoirs, and portability studs.

With these **PMA Solutions**, you can expect:

- Reduced lead time with in-stock inventory
- The same quality as the OEM alternative
- Lower cost in comparison to the OEM part

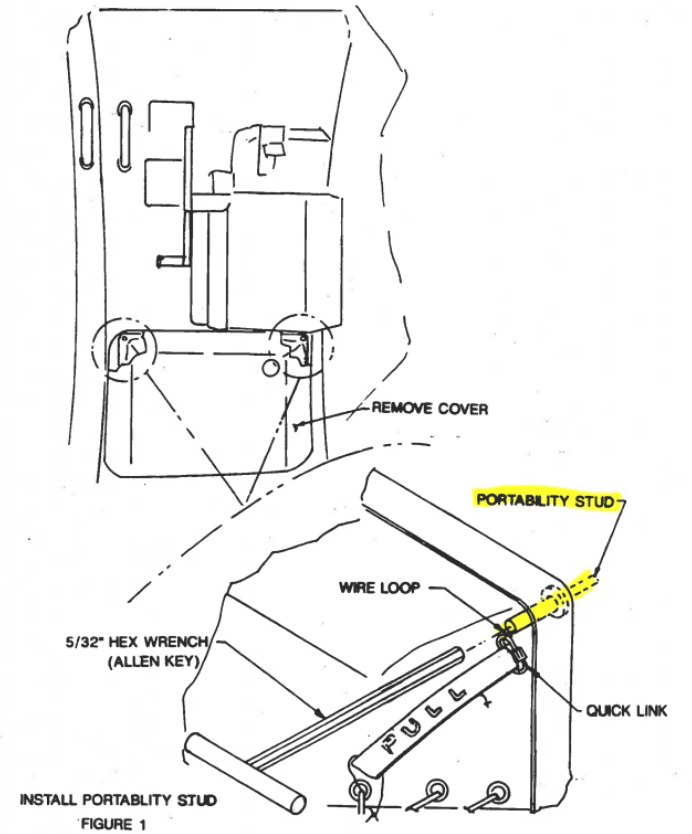

AVI Aviation's Top Selling PMA Parts



Article Name	Parts	Approved Replacement for Part#	Make Eligibility	Model Eligibility
Reservoir	4a3057AI	4A3057	Boeing	747-100/-200B/-200C/-300/ 747SP
Cylinder	630124-04AI	630124-04	Boeing & Airbus	737-600/-700/-700C/-800/-900/-900ER A330-201/-202/-203/-223/-243/-301/-303/-321/-322/-323/-341/-342/-343/ A340-211/-212/-213/-311/-312/-313/-541/-642
Cylinder	630124-05AI	630124-05	Boeing & Airbus	767-200/-300/-300F/-400ER A330-201/-202/-203/-223/-243/-301/-303/-321/-322/-323/-341/-342/-343 A340-211/-212/213/-311/-312/-313/-541/-642
Reservoir	630124-10AI	630124-10	Boeing	767-200/-300/-300F/-400
Cylinder	64037-1AI	64037-1	Boeing & Airbus	Various Fleet Applications
Reservoir	64206-1AI	64206-1	Boeing	757-200/-200PF/-200CB/-300
Reservoir	64206-3AI	64206-3	Boeing	757-200/-200PF/-200CB/-300
Cylinder	64207-1AI	64207-1	Boeing	757-200/-200PF/-200CB/-300
Reservoir	64236-1AI	64236-1	Airbus	A318 /A319/A320/A321
Cylinder	64331-1AI	64331-1	Airbus	A318 /A319/A320/A321
Reservoir	630124-06AI	630124-06	Boeing	B747-100, -200, B747SP
Reservoir	630124-11AI	630124-11	Boeing	B747, B767, DC-9, MD-90
Cylinder	533-165	533-165AI	Boeing & Airbus	Various Fleet Applications
Cylinder	102-1AI	102-1AI	Boeing & Airbus	Various Fleet Applications
Cylinder	64037-1AI		Boeing & Airbus	Various Fleet Applications
Stud, Portability	62158-101AI	62158-101	Airbus	A319, A320, A321

AVI Aviation's PMA Girt Assembly

AVI Aviation offers PMA Girt Assembly for Boeing 737 5A3307-701 and 5A3307-9.

Features and Functionality:

- Constructed of a high-strength, urethane-coated nylon fabric with an aluminized coating to protect against radiated heat. It is a crucial component of the emergency evacuation slide for passenger and crew evacuation.
- Connects the slide to the aircraft door and automatically deploys when opened during an emergency.
- Inflate after the pack ejects, ensuring a safe and efficient evacuation process.



First Class Air Support Roller Systems



First Class Air Support is the exclusive distributor of PMA Roller Systems, offering reduced cost, lower lead time, and available inventory.

Our PMA Roller Systems:

- Decrease the number of repairs needed from 6 months to a year with our PMA Roller System
- Decreased amount of wear and tear on Unicasters due to dirt and grease
- And increased effectiveness by using polymer over the aluminum used for the OEM alternative

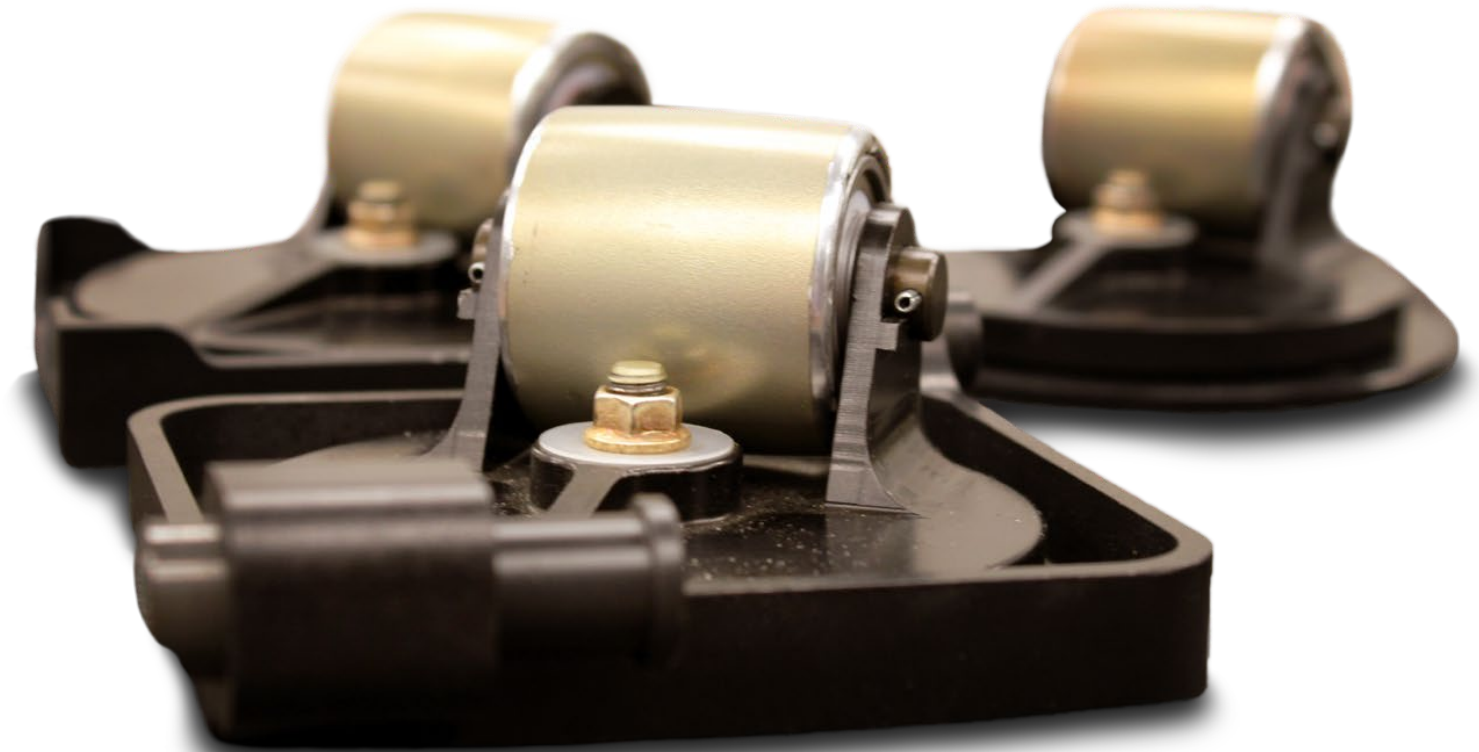



Thank You!
Questions?